

W A T E R A N D D R A I N A G E

- ▶ Drainage Around Walls
- ▶ Drainage Structures
- ▶ Water Applications

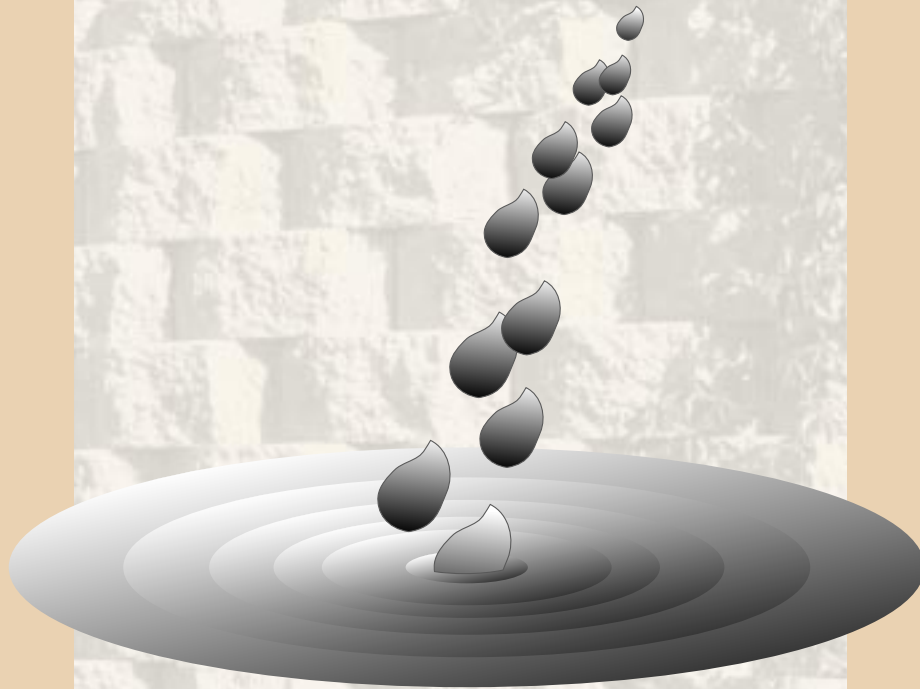

Poor drainage is a leading cause of retaining wall failures. Hydrostatic pressure can accumulate behind a wall if drainage is inadequate, add an increased load on the wall. The Keystone® system has superior drainage features. The techniques below should be considered where the specified drainage issues are present.

1. **BASIC DRAINAGE.** Keystone's® mortarless, interlocking system, with a free draining gravel drainage zone and corefill (see "INSTALLATION STEP BY STEP" section), allow proper drainage under most circumstances. No weep holes are necessary.
2. **SURFACE RUN-OFF.** Divert surface drainage at the top of the retaining wall by placing a plastic soil cap (i.e., clay) or formed swale (i.e., soil or concrete) along the back surface of the Keystone® units. Direct run-off away from the reinforced wall structure where possible.
3. **EMBANKMENT FLOW.** Where embankment ground water flow behind the wall is likely, place an embankment drainage membrane over the cut soil (see product suppliers for recommended coverage and installation instructions). The embankment membrane should drain to an outflow pipe (i.e., drain tile) to remove water. Numerous cost-effective products are available to serve this purpose.
4. **GROUND WATER FLOW.** The effects of seasonally fluctuating ground water at the base of the retaining wall can be offset by placing a drainage zone of gravel with an outflow pipe (i.e., drain tile) beneath the leveling pad.

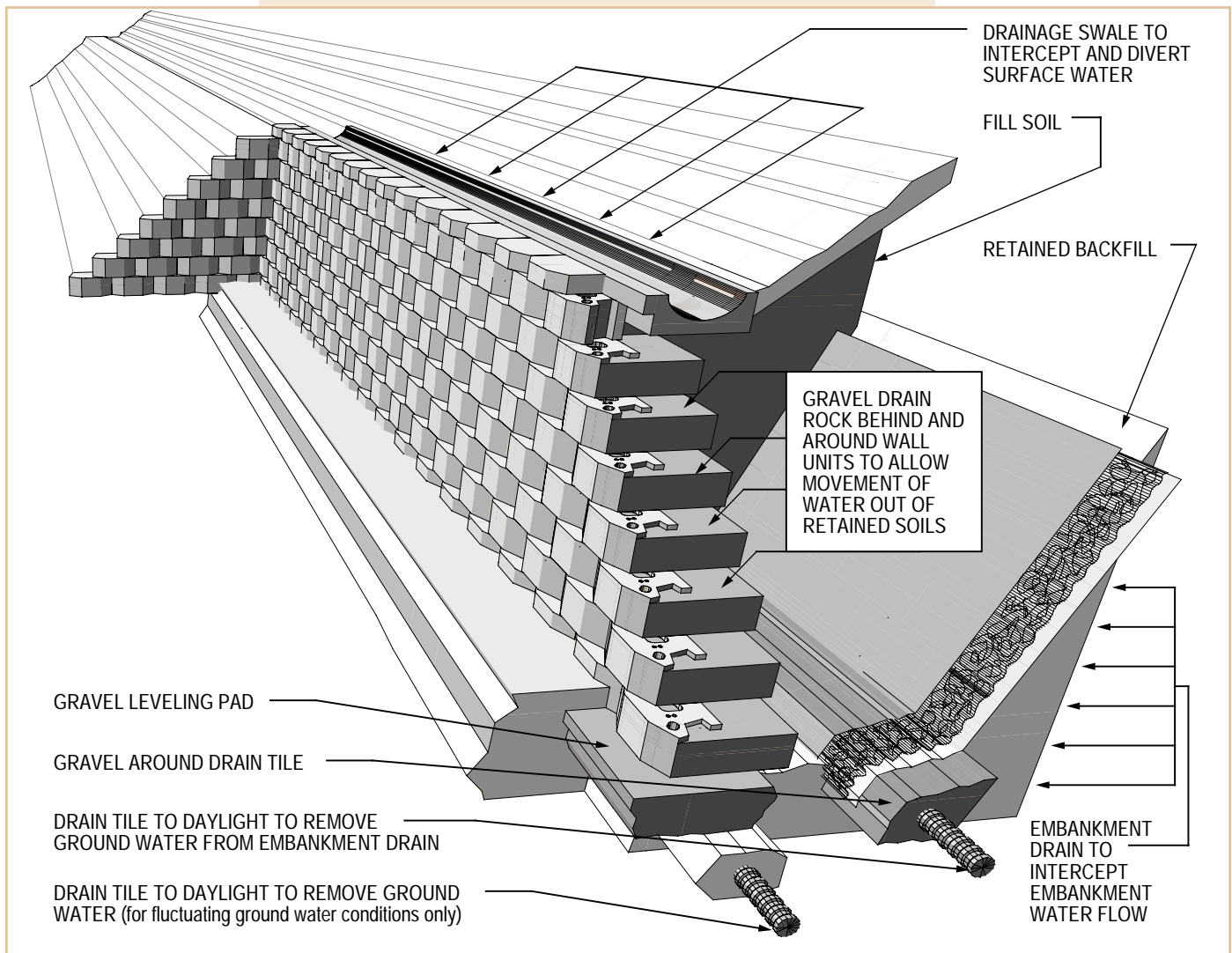

WATER AND DRAINAGE

▷ DRAINAGE STRUCTURES

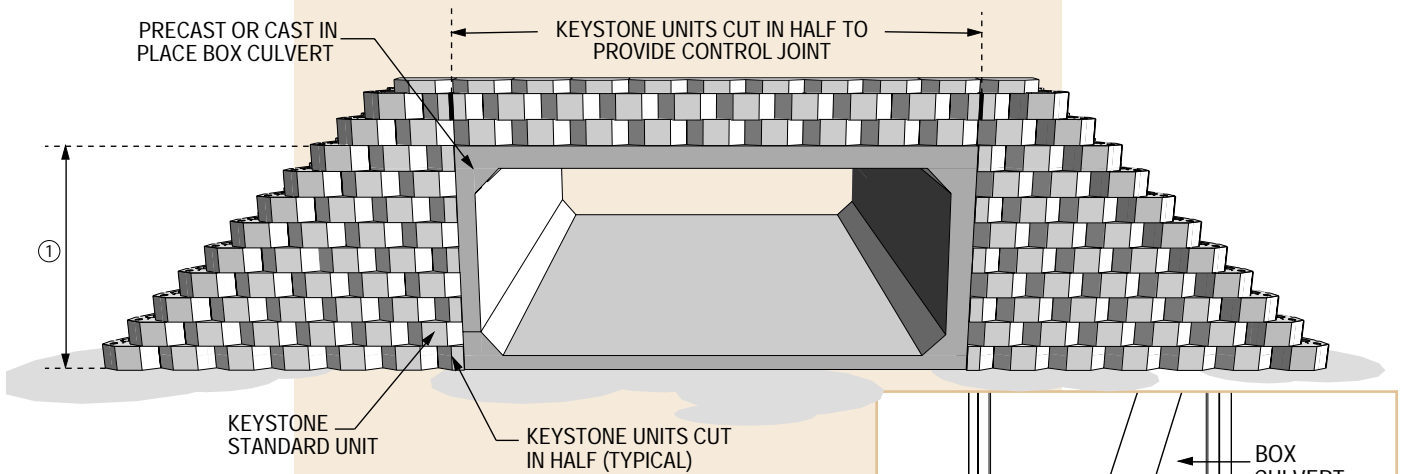

① NOTE: Design of box culvert with KEYSTONE Retaining Wall units works best if culvert height is in even 8" (200mm) increments to line up with KEYSTONE coursing and width aligns with full increments of KEYSTONE UNITS (18")(457mm).

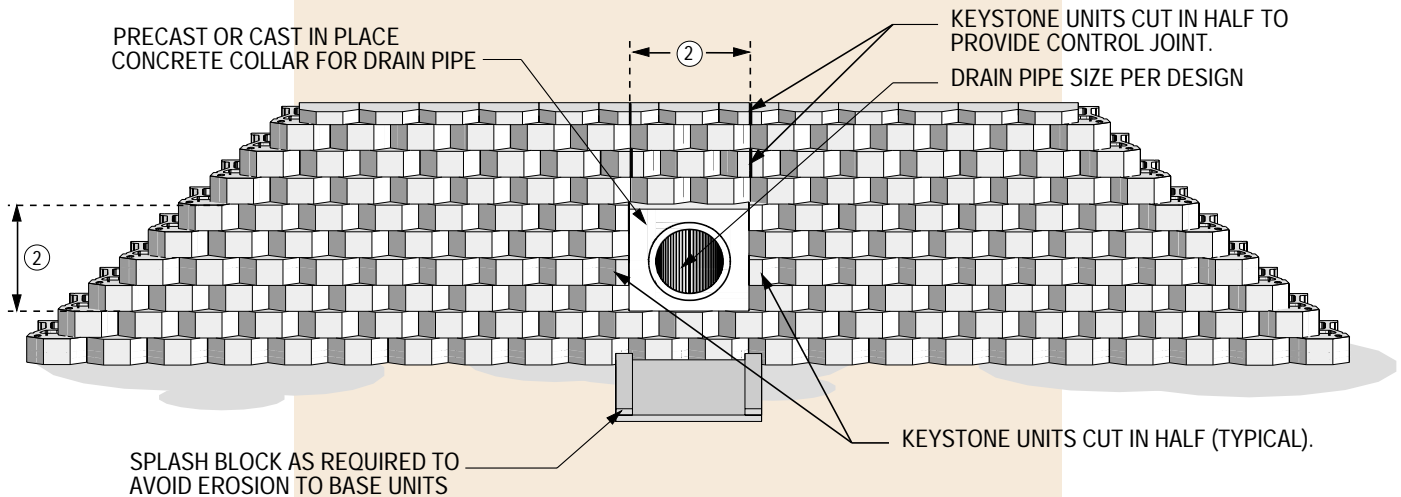
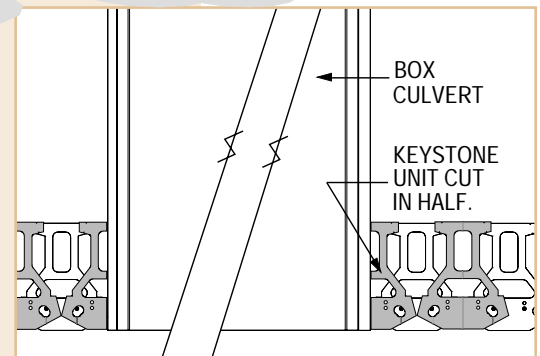

② NOTE: Design of drain pipe with KEYSTONE Retaining Wall units works best if culvert height is in even 8" (200mm) increments to line up with KEYSTONE coursing and width aligns with full increments of KEYSTONE units (18")(457mm).

OPTION: On smaller scale drainage structures, the designer or contractor may choose to field cut the KEYSTONE units to conform to the shape of the pipe. Voids between units and pipe can be filled in with mortar or sealant material.

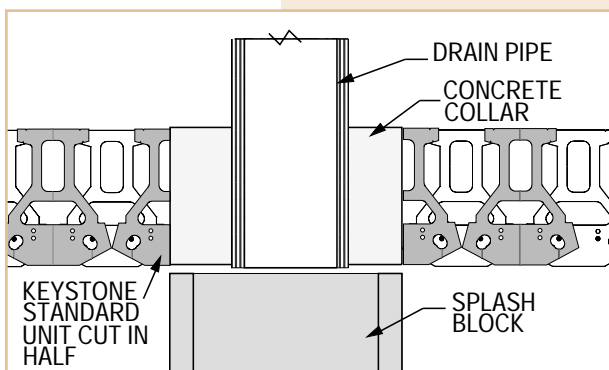

WATER AND DRAINAGE

▶ DRAINAGE STRUCTURES

Keystone Retaining Walls are an ideal system for economical and effective use with steel multi-plate arch design:

INSTALLATION:

- ▶ Cut Keystone units to conform to arch. Maximum gap 3/4" (15mm) to be grouted with low shrink grout.
- ▶ When building the Keystone wall, backfill the reinforced zone in equal lifts on each side of the arch according to manufacturers requirements in order to even out load distribution during construction.
- ▶ Measure for exact course height and unit bonding on each side of arch so they meet correctly at top of arch.
- ▶ Fascia collar of hot rolled steel angle section will help conceal rough cut Keystone edges and give an aesthetically appealing final finish.

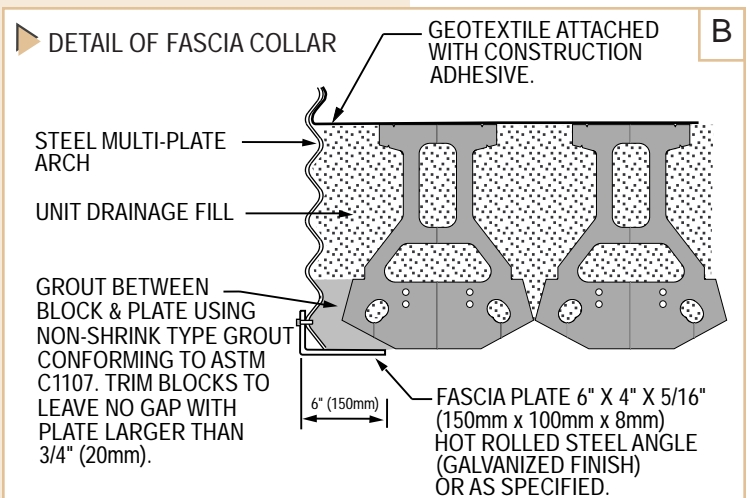
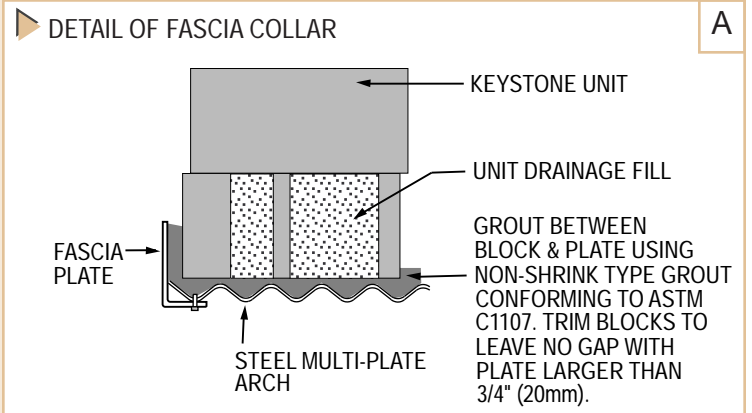
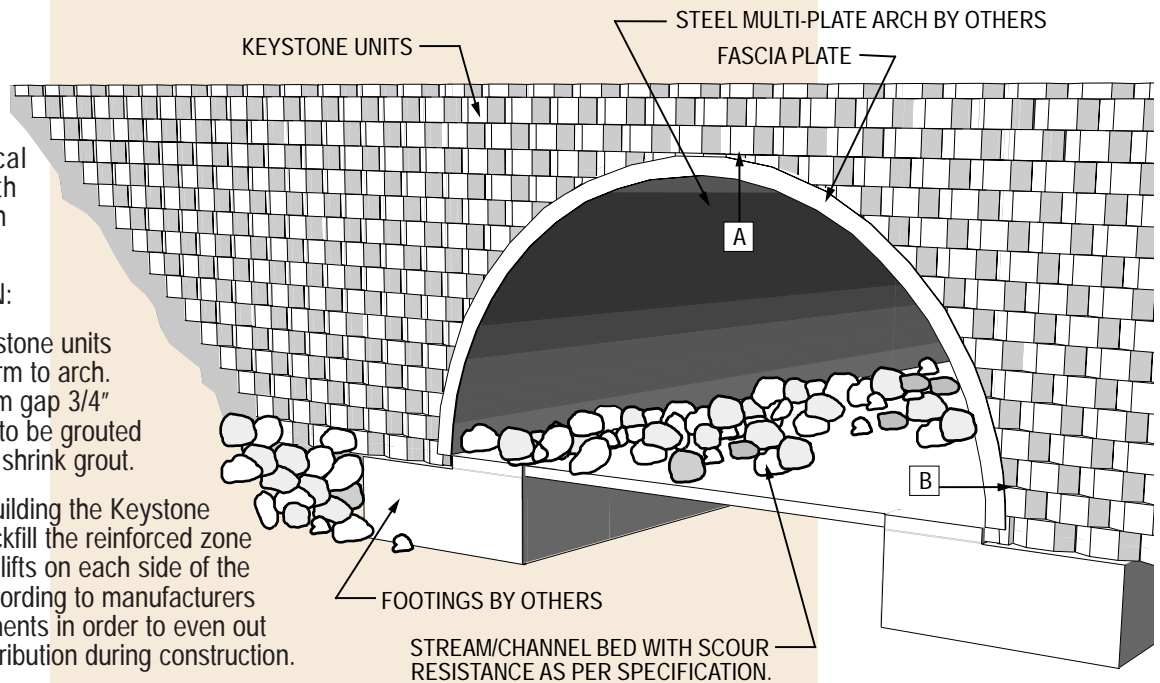

The information contained herein has been compiled by Keystone® Retaining Wall Systems, Inc. and to the best of our knowledge, accurately represents the Keystone product use in the applications which are illustrated. Final determination of the suitability for the use contemplated and its manner of use are the sole responsibility of the user. Structural design and analysis shall be performed by a qualified engineer.
© 1997 KEYSTONE RETAINING WALL SYSTEMS, INC.
Minneapolis, Minnesota • (612) 897-1040 • (612) 897-3858-fax

WATER AND DRAINAGE

▷ DRAINAGE STRUCTURES

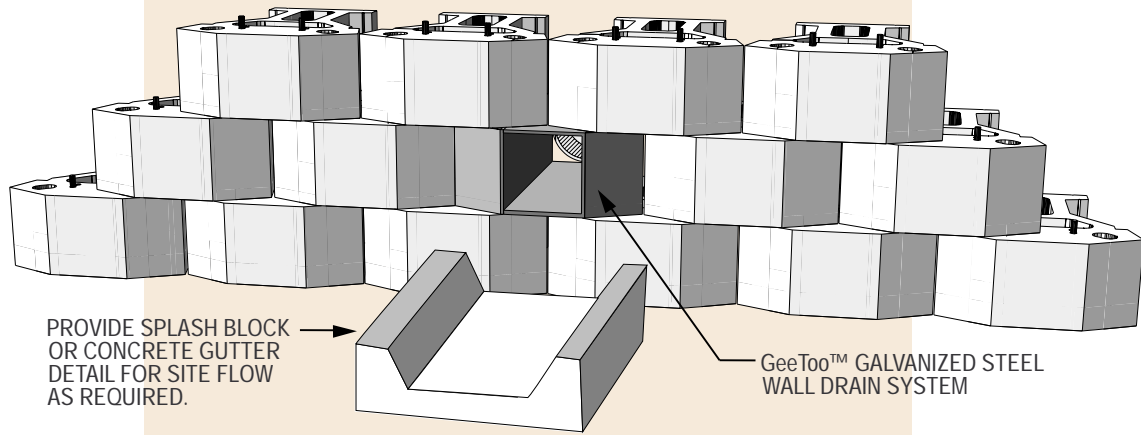

PROVIDE SPLASH BLOCK OR CONCRETE GUTTER DETAIL FOR SITE FLOW AS REQUIRED.

GeeToo™ GALVANIZED STEEL WALL DRAIN SYSTEM



▷ Integrated in running bond pattern into the Keystone Retaining Wall

▷ Built to handle the water force of storm drain systems.

▷ Locks solid into the Keystone System with grout fill at pin connection.

As a means to design for site drainage lines which intersect with the Keystone walls in a professional and high aesthetic manor, the following drain system gives you the quality solution.

The "GeeToo™ DRAINS" were developed by Wiley & Associates, Inc. to perform the task of linking site drainage lines from building or storm systems allowing them to terminate with surface outflow through the face of the Keystone Retaining Wall.

The system utilizes a 16 gauge mild steel (galvanized) housing with an 8" (200mm) I.D. adapter pipe tail for connection to the site drain line. The total housing occupies the space of one full Keystone unit, locking into the shear pin system and supporting additional courses above.

GeeToo™ DRAINS available to match "3-plane split or straight split" Keystone units.

For more information or to place an order, contact:

Wiley & Associates, Inc.
3200 North Hayden Road
Scottsdale, Arizona 85251
(602) 947-7507
U.S. Patent Number 5,425,600

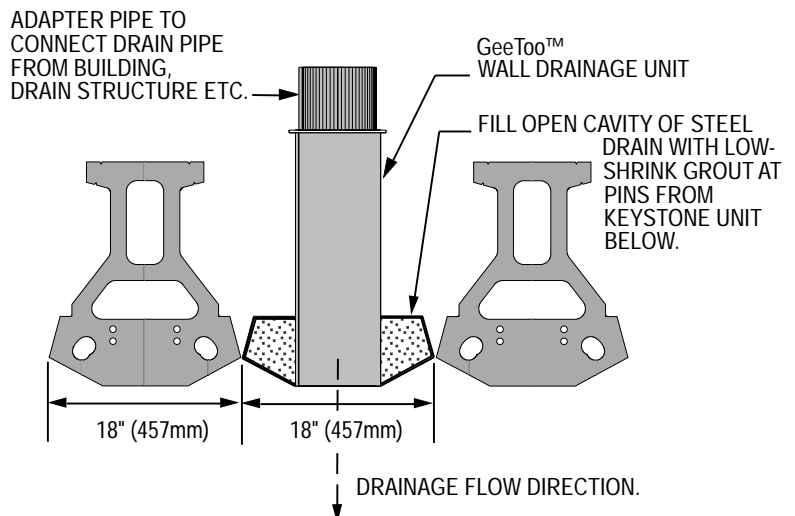

When considering a water application for the Keystone Wall System, the following areas need to be analyzed and designed to maintain structural integrity of the wall under normal, high wave and flooding water conditions:

- Start by analyzing the wall under normal design criteria. (i.e. WALL HEIGHT, BASE CONDITIONS, SURCHARGE LOADS, SOILS DATA, REINFORCEMENT REQUIREMENTS, DRAINAGE, ETC.)
- Determine the water level on wall under normal and adverse conditions.
- Determine flow rate for streams, channels, etc.
- Determine degree of wave action; minor, major or boat wake.
- Determine the potential for flooding and inundation of the wall.

Once these items have been evaluated, design options to handle these conditions can be selected.

CONDITION: Soft base soils subject to settlement and erosion.

OPTIONS: A foundation mattress constructed of filter membrane, crushed stone and geogrid reinforcement will support the wall and reinforced zone over soft base conditions. Filter membrane prohibits migration of fines into stone of mattress area. The mattress is free draining and resists erosion from under the wall. This solution also permits construction where base of wall is below the water elevation (see detail on following page).

In more extreme conditions, a continuous reinforced concrete footing may be required to avoid settlement. This can be additionally structured to combine with pile or concrete casons for support by more capable soils at a deeper elevation (see detail on following page).

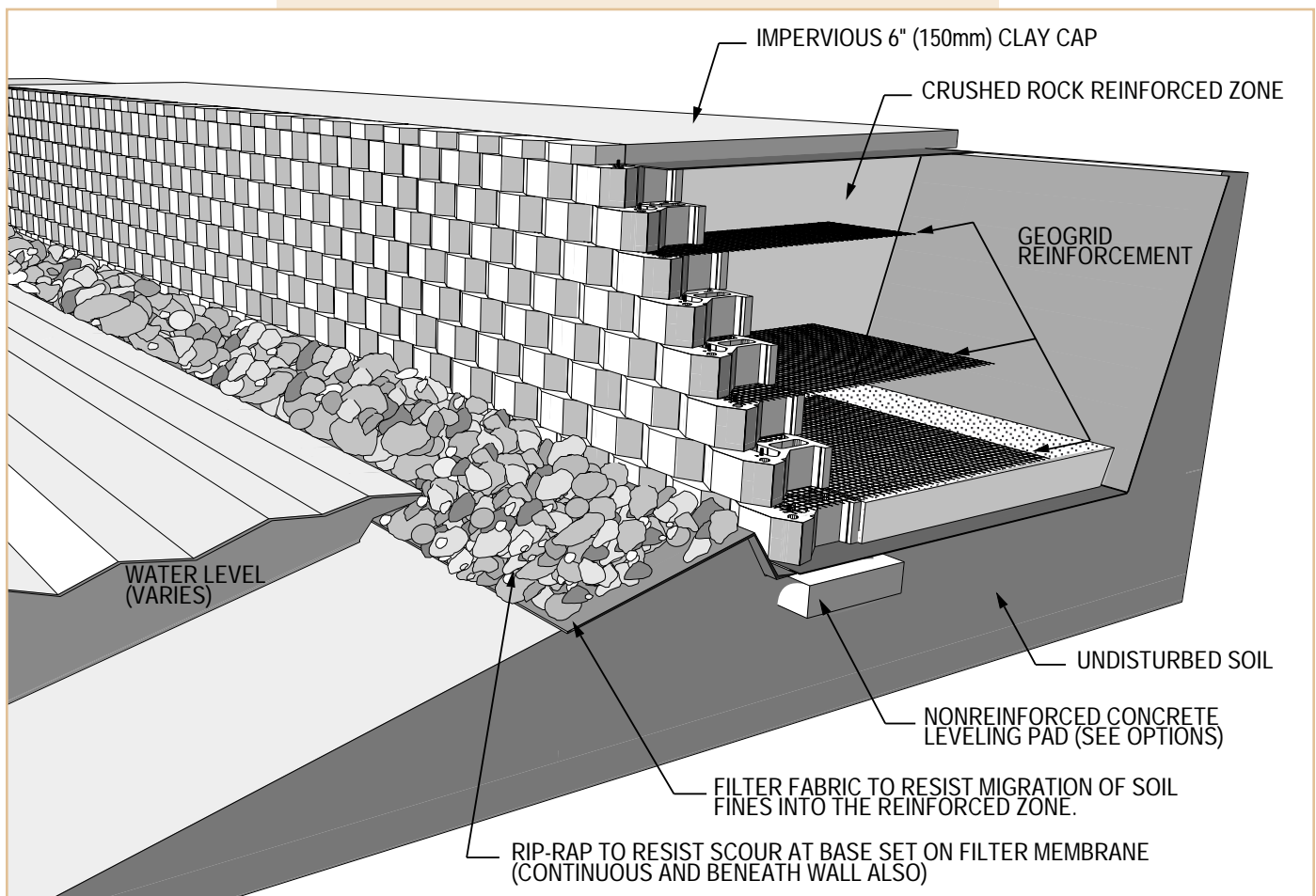

CONDITION: Scour potential at toe of wall due to water flow and wave action.

OPTION: The use of natural stone rip rap on a filter membrane is a possible solution depending on degree of flow and wave action. Distance out from wall toe and size of rip rap will be determined by degree of water flow.

In more extreme cases, the use of cable tied articulated concrete revetment systems along the sloped base and beneath the wall can resist the heavy water flow and wave action (see detail below).

CONDITION: Rapid draw down after flooding or waves going over wall and adding hydrostatic surcharge to wall loading.

OPTION: Design using hydrostatic loads as well as normal loads in determining the reinforcement requirements. Use free draining crushed stone in reinforced zone to permit rapid outflow of water through the wall. Provide filter membrane on top of reinforced zone below turf soils or clay cap to allow drainage without migration of organic fines into free draining reinforced zone crushed rock (see detail on previous page).

▷ FOUNDATION MATRESS

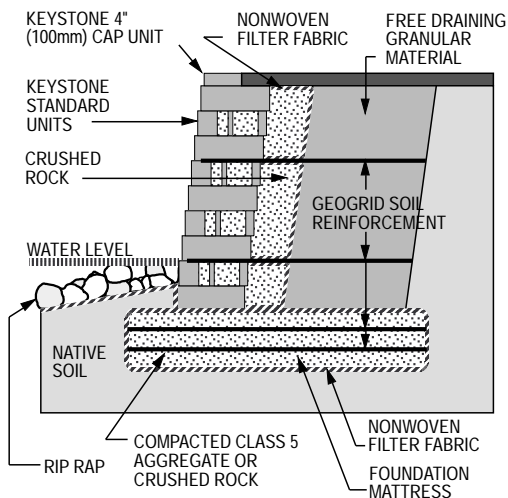

▷ PILE OR CASSION SUPPORT

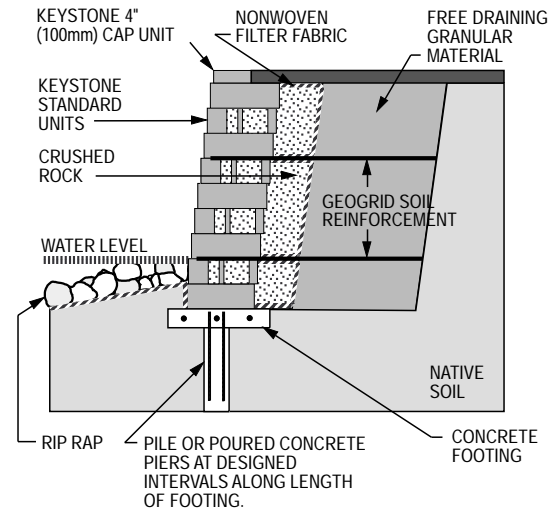

▷ CONCRETE FOOTING

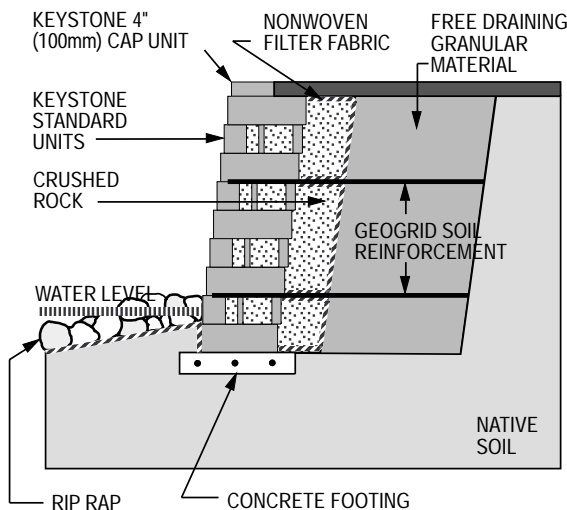

▷ REVETMENT SYSTEM

